

LF150-10M



LF150-10M F-01 灯具 LIGHTS

F-01 灯具 LIGHTS



Id		PartName	Description	Unit
F01-01	QJM33100A0A00	前照灯总成	Headlight Assy	PC
F01-02	QJM33550A0A00	前左转向灯	Front Winker, LH	PC
F01-03	QJM33510A0A00	前右转向灯	Front Winker, RH	PC
F01-04	QJM33650A0A00	后左转向灯	Rear Winker, LH	PC
F01-05	QJM33610A0A00	后右转向灯	Rear Winker, RH	PC
F01-06	QJM33700A0A00	尾灯总成	Taillight Assy	PC
F01-07	QJM33760A0A00	牌照灯组合	Light comp., license plate	PC

LF150-10M F-02 仪表总成 METER ASSY

F-02 仪表总成 METER ASSY



Id		PartName	Description	Unit
F02-01	QJM43111A0R07	前照灯护罩	Housing, headlight	PC
F02-02	QJM43131A0A00	仪表护罩	Case, meter	PC
F02-03	QJM33920A0B01	前照灯支架组件	Stay set, headlight	PC
F02-04	QJM33910A0B01	前照灯支架组合	Stay comp., headlight	PC
F02-05	QJM35951A0A00	点火开关罩	Hood, ignition switch	PC
F02-06	QJM37000A0A00	仪表总成	Meter Assy	PC

LF150-10M F-03 握把 开关 GRIP & SWITCH

F-03 握把 开关 GRIP & SWITCH



Id		PartName	Description	Unit
F03-01	QMA57100A2A00	右后视镜	Rearview Mirror	PC
F03-02	QMA57200A2A00	左后视镜	Rearview Mirror	PC
F03-03	QJM46300A0A00	油门拉索	Throttle Cable	PC
F03-04	JJM46350A0A00	阻风门拉索	Cable, choke	PC
F03-05	QJM46200A0A00	离合拉索	Clutch Cable	PC
F03-06	QJM47110A0B15	方向把管组件	Steering Bar Pipe Comp.	PC
F03-07	QJZ47600A0B01	离合器手柄组合	Clutch Lever Holder Set	PC
F03-08	QJZ47370A0B01	方向把平衡块组合	Steering Bar Weight Set	PC
F03-09	QJM35200A0A00	左手把开关	Handlebar Switch, LH	PC
F03-10	QJM35100A0A00	右手把开关	Handlebar Switch, RH	PC
F03-11	QJZ47411A0B01	左握把	Grip Comp., LH	PC
F03-12	QJZ47300A0B01	油门握把组合	Throttle Grip Comp.	PC

LF150-10M F-04 方向柱 STEERING STEM

F-04 方向柱 STEERING STEM

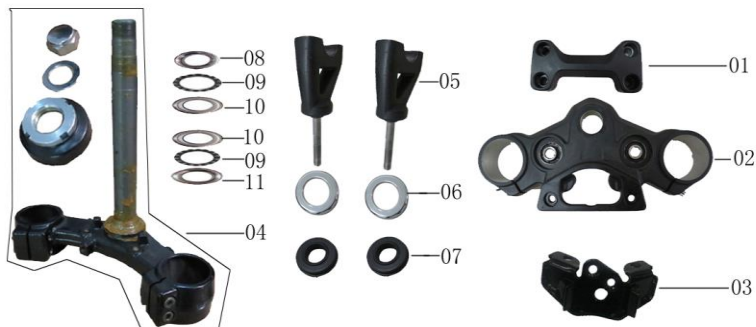

Id		PartName	Description	Unit
F04-01	XXXXXXXXXXXXX	方向把卡夹	Holder Cap	PC
F04-02	QJM51300A0B03	上联板组合	Top Steering Stem Connection Board	PC
F04-03	QJM35940A0B01	点火开关支架组件	Stay set, ignition switch	PC
F04-04	QLR51210A2B03	方向柱组件	Steering Stem Assy	PC
F04-05	XXXXXXXXXXXXX	方向把管固定座组件	Holder set, steering bar pipe	PC
F04-06	ZMD51313A0M01	方向柱上装饰盖	Cushion Cover, Steering Stem	PC
F04-07	ZMD51214A0A00	方向柱上减震垫	Upper Cushion, Steering Stem	PC
F04-08	QJX51951A0A00	上轴承上盖	Steering Stem Bearing Set	PC
F04-09	QJX51950A1A00	方向轴承组件	Pipe set, steering bar	SET
F04-10	QJX51952A0A00	上轴承下盖	Lug, speed sensor	PC
F04-11	QJZ51954A0A00	下轴承下盖	Pipe set, steering bar	PC

LF150-10M F-05 前挡泥板 减震器 FRONT FENDER & SHOCK ABSORBER

F-05 前挡泥板 减震器 FRONT FENDER & SHOCK ABSORBER



Id		PartName	Description	Unit
F05-01	NIX33810A0A00	前反射器	Reflector, front	PC
F05-02	QJM33980A0B03	反射器左支架组件	side reflector braket comp.LH	PC
F05-03	QJM52500A0B02	前左减震器	Shock absorber, front, LH	PC
F05-04	QJM53920A0B03	前左挡泥板支架组件	front left fender braket comp.	PC
F05-05	QJM53910A0B03	前右挡泥板支架组件	front right fender braket comp.	PC
F05-06	QJM52400A0B02	前右减震器	Shock absorber, front, RH	PC
F05-07	QJM33850A0B03	反射器右支架组件	side reflector braket comp.RH	PC
F05-08	QJM62100A0M01	后减震器总成	Shock absorber Assy, rear	PC
F05-09	QLR53111A2R07	前挡泥板	Front Fender Assy	PC
F05-10	QJM33936A0N04	线夹	Clamp	PC

LF150-10M F-06 侧盖 SIDE COVER

F-06 侧盖 SIDE COVER

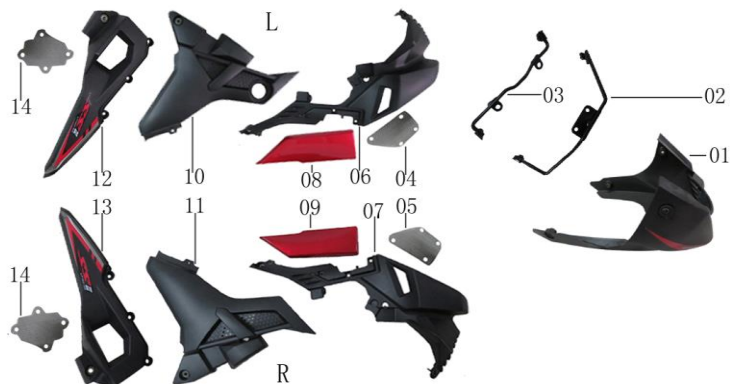

Id		PartName	Description	Unit
F06-01	XXXXXXXXXXXXX	下护板	Guard, lower	PC
F06-02	QJM43810A0B01	前导流罩支架组合	Stay comp., front fairing	PC
F06-03	QJM43920A0B01	前导流罩下支架组件	Stay set, front fairing bottom	PC
F06-04	QJM43416A0H04	左装饰罩护网	Gauze, ornament, LH	PC
F06-05	QJM43316A0H04	右装饰罩护网	Gauze, ornament, RH	PC
F06-06	QJM43545A0A00	油箱左装饰罩	Ornament, fuel tank, LH	PC
F06-07	QJM43541A0A00	油箱右装饰罩	Ornament, fuel tank, RH	PC
F06-08	QJM49121A0R07	油箱左装饰罩II	Ornament II, fuel tank, LH	PC
F06-09	QJM49111A0R07	油箱右装饰罩II	Ornament II, fuel tank, RH	PC
F06-10	QJM43411A0A00	左侧盖	Cover, side, LH	PC
F06-11	QJM43311A0A00	右侧盖	Cover, side, RH	PC
F06-12	XXXXXXXXXXXXX	左侧盖装饰罩	Ornament, side cover, LH	PC
F06-13	XXXXXXXXXXXXX	右侧盖装饰罩	Ornament, side cover, RH	PC
F06-14	XXXXXXXXXXXXX	侧盖内板	Lining, side cover,	PC

LF150-10M F-07 油箱 FUEL TANK

F-07 油箱 FUEL TANK



Id		PartName	Description	Unit
F07-01	QJZ16951A0A00	油箱前减震垫	Cushion, fuel tank front	PC
F07-02	QJM16610A0R07	油箱组合	Tank weldment, fuel	PC
F07-03	QJZ16995A0A00	油箱后减震垫	Cushion, fuel tank rear	PC
F07-04	QJM48000A0A00	锁具总成	Lock Assy	PC
F07-05	JLC16810A0N03	燃油开关组合	Cock comp., fuel	PC
F07-06	QJM16818A0A00	燃油开关手柄	Handle, fuel cock	PC
F07-07	QJM37810A0A00	燃油传感器	Sensor, fuel	PC

LF150-10M F-08 后围板 REAR PANEL

F-08 后围板 REAR PANEL



Id		PartName	Description	Unit
F08-01	XXXXXXXXXXXXX	左后围板	Panel, rear, LH	PC
F08-02	QJM63151A0A00	后挡泥板后体	Tail, rear fender	PC
F08-03	XXXXXXXXXXXXX	右后围板	Panel, rear, RH	PC
F08-04	QJM34940A0B01	点火控制器支架组件	Bracket set, ignition controller	PC
F08-05	QJM43611A0A00	工具箱	Box, tool	PC
F08-06	QJM33783A0B01	尾灯座安装板	Plate, taillight socket	PC

LF150-10M F-09 后挡泥板 REAR PENDER

F-09 后挡泥板 REAR FENDER

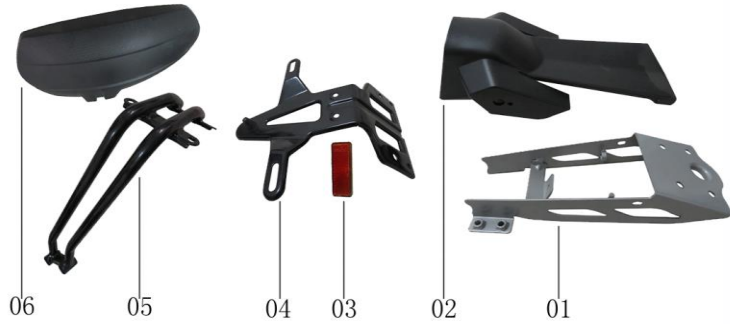

Id		PartName	Description	Unit
F09-01	QJM63950A0H04	后挡泥板后体支架组件	Bracket set, rear body	PC
F09-02	QJM63311A0A00	后挡泥板尾翘	Wing, rear fender tail	PC
F09-03	ZJA33820A0A00	后反射器	Reflector, rear	PC
F09-04	QJM63711A0B01	后牌照支架	Bracket, rear license plate	PC
F09-05	QJM63920A0B01	后挡泥板前体后支架组件	Bracket set, front body rear	PC
F09-06	QJM63111A0A00	后挡泥板	Fender, rear	PC

LF150-10M F-10 前轮 FRONT WHEEL

F-10 前轮 FRONT WHEEL



Id		PartName	Description	Unit
F10-01	XXXXXXXXXXXX	螺母M12×1.25	Nut, M12×1.25	PC
F10-02	QJS37870A1A00	速度传感器组合	Sensor, speed	PC
F10-03	QLR54100A2B03	前轮毂组合	Hub comp., front wheel	PC
F10-04	QJM54700A0A00	前轮外胎	Tyre, front	PC
F10-05	QJS56311A0B01	前制动盘	Disc, front brake	PC
F10-06	QJZ54912A0N04	前轮右衬套	Bush, front wheel, RH	PC
F10-07	ZJX54911A0N04	前轮轴	Shaft, front fork	PC

LF150-10M F-11 后叉 REAR FORK

F-11 后叉 REAE FORK

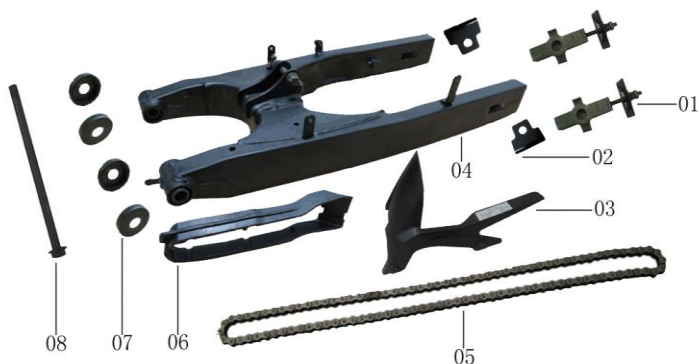

Id		PartName	Description	Unit
F11-01	QJM61400A1A00	链条调节器组合	Adjuster set, chain	PC
F11-02	XXXXXXXXXXXXX	链条调节器定位板	Plate, chain adjuster setting	PC
F11-03	QJM61311A0A00	链盒	Chaincase	PC
F11-04	QJM61101A0B01	后叉组合	Fork comp., rear	PC
F11-05	Q980428MH128C	链条428MH×128	Chain,	SET
F11-06	QLR61491A1A00	链条护卡	Guide, chain	PC
F11-07	QLL61240A0N04	后叉轴防尘盖组件	Dust cover, rear fork shaft	PC
F11-08	QIX61951A0N04	后叉轴	Shaft, rear fork	PC

LF150-10M F-12 后轮 REAR WHEEL

F-12 后轮 REAR WHEEL

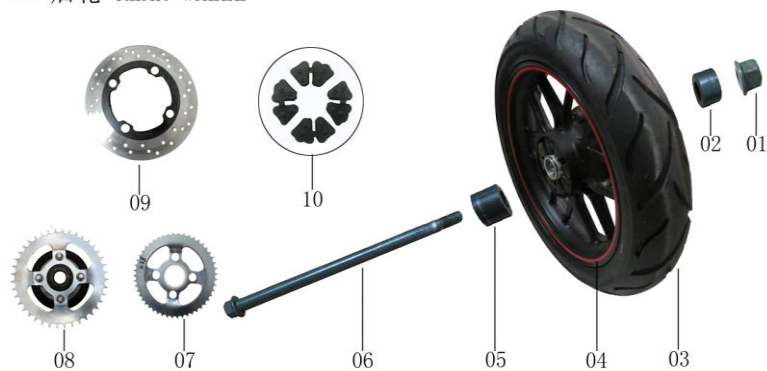

Id		PartName	Description	Unit
F12-01	XXXXXXXXXXXX	螺母	Nut,	PC
F12-02	QJZ64912A0N04	后轮右衬套	Rear Wheel Bush, RH	PC
F12-03	QJM64700A0A00	后轮外胎	Tyre, rear	PC
F12-04	QLR64100A1B03	后轮毂组合	Hub, rear wheel	PC
F12-05	QJZ64913A0N04	后轮左衬套	Rear Wheel Bush, LH	PC
F12-06	Q13114310T1F35	轴A14×310	Axle, rear	PC
F12-07	XXXXXXXXXXXX	链轮	Sprocket	PC
F12-08	QJM68500A0A00	链轮毂总成	Hub Assy, sprocket	PC
F12-09	QJZ66311A1A00	后制动盘	Disc, rear brake	PC
F12-10	XXXXXXXXXXXX	后轮缓冲块	Buffer, rear wheel	PC

LF150-10M F-13 坐垫 & 空滤器 SEAT & AIR CLEANER

F-13 坐垫 & 空滤器 SEAT & AIR CLEANER



Id		PartName	Description	Unit
F13-01	XXXXXXXXXXXX	空滤器滤芯II	Element II, air cleaner	PC
F13-02	QJZ17100A6A00	空气滤清器总成	Cleaner Assy, air	PC
F13-03	XXXXXXXXXXXX	空滤器滤芯组件	Element, air cleaner	PC
F13-04	QJM44100A0A00	前坐垫总成	Seat Assy, rider	PC
F13-05	QJM44300A0A00	后坐垫总成	Pillion Assy	PC

LF150-10M F-14 排气消声器 EXHAUST MUFFLER

F-14 排气消声器 EXHAUST MUFFLER

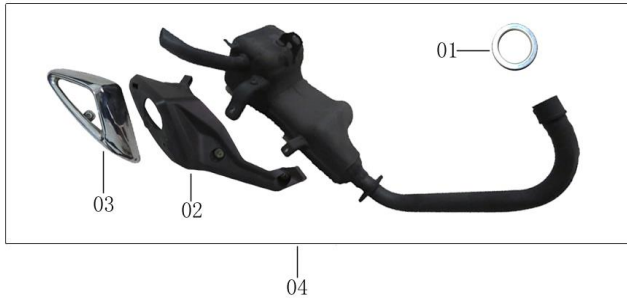

Id		PartName	Description	Unit
F14-01	XXXXXXXXXXXXX	消声器密封垫组件	Gasket set, muffler	PC
F14-02	XXXXXXXXXXXXX	消声器护罩	Mantle, muffler	PC
F14-03	XXXXXXXXXXXXX	消声器装饰罩组件	Ornament set, muffler	PC
F14-04	QJM18000A0B11	排气消声器总成	Muffler Assy, exhaust	PC

LF150-10M F-15 前后制动器 FRONT & REAR BRAKE

F-15 前后制动器 FRONT&REAR BRAKE

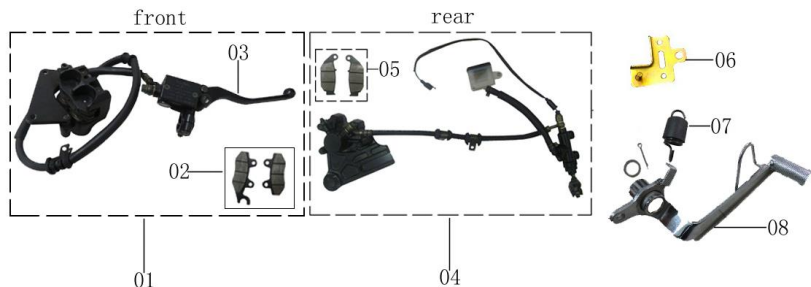

Id		PartName	Description	Unit
F15-01	QJM56010A0A00	前液压制动器组合	Brake comp., front hydraulic	PC
F15-02	XXXXXXXXXXXXXX	前制动蹄片	Front Brake Shoe Set	PC
F15-03	XXXXXXXXXXXXXX	前制动手柄	Front Brake Lever	PC
F15-04	QJZ66010A1A00	后液压制动器组合	Rear Hydraulic Disc Brake	PC
F15-05	XXXXXXXXXXXXXX	后制动蹄片	Rear Brake Shoe Set	PC
F15-06	QJZ66940A0N03	后制动油杯安装支架组件	Bracket set, rear brake reservoir	PC
F15-07	QJZ65940A1N04	后制动踏板回位簧组件	Spring set, rear brake pedal	PC
F15-08	QJM65410A0M01	后制动踏板组合	Pedal, rear brake	PC

LF150-10M F-16 主支架 CENTER STAND

F-16 主支架 CENTER STAND



Id		PartName	Description	Unit
F16-01	ZJA42913A0N04	主支架回位弹簧	Spring, center stand return	PC
F16-02	QJM42140A0N04	主支架左下支撑组件	Support set, center stand lower	PC
F16-03	QJM42100A0B01	主支架	Stand, center	PC
F16-04	QJM42210A0B01	侧支架	Stand, side	PC
F16-05	QJX42922A0N04	侧支架回位弹簧	Spring, side stand return	PC
F16-06	QJM42130A0N04	主支架右下支撑组件	Support set, center stand lower	PC

LF150-10M F-17 搁脚组合 FOOTRESTS

F-17 搁脚组合 FOOTRESTS

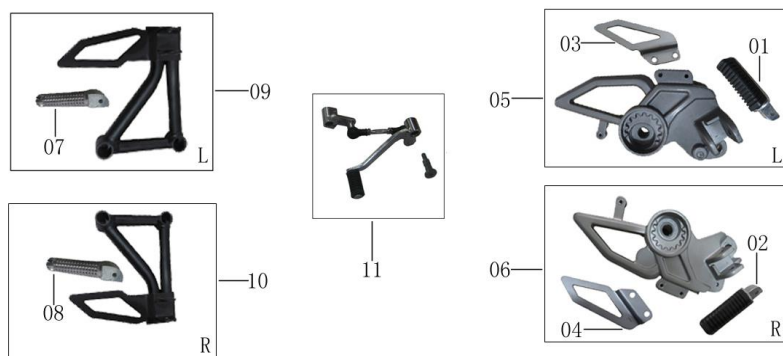

Id		PartName	Description	Unit
F17-01	XXXXXXXXXXXXX	前左搁脚组合	Footrest comp., rider, LH	PC
F17-02	XXXXXXXXXXXXX	前右搁脚组合	Footrest comp., rider, RH	PC
F17-03	QJM42487A0H05	前左搁脚装饰板	Ornament, Footrest LH	PC
F17-04	QJM42387A0H05	前右搁脚装饰板	Ornament, Footrest RH	PC
F17-05	QJM42400A1H05	前左搁脚总成	Footrest comp., rider, LH	PC
F17-06	QJM42300A1H05	前右搁脚总成	Footrest comp., rider, RH	PC
F17-07	XXXXXXXXXXXXX	后左搁脚踏板	Treadle, pillion, LH	PC
F17-08	XXXXXXXXXXXXX	后右搁脚踏板	Treadle, pillion, RH	PC
F17-09	QJM42610A1B03	后左搁脚组合	Footrest comp., pillion, LH	PC
F17-10	QJM42510A1B03	后右搁脚组合	Footrest comp., pillion, RH	PC
F17-11	XXXXXXXXXXXXX	换挡杆总成	Lever, gearshift	PC

LF150-10M F-18 车架总成 FRAME BODY

F-18 车架总成 FRAME BODY

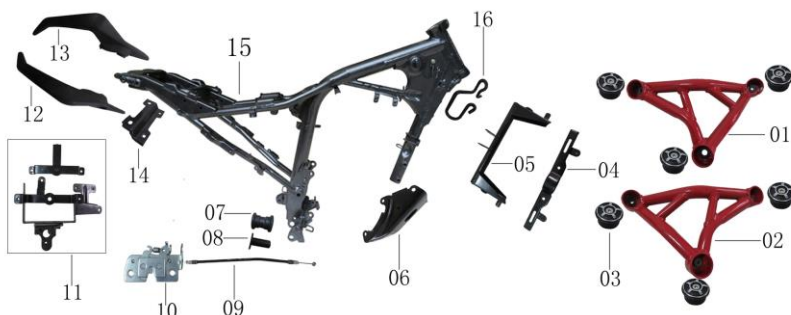

Id		PartName	Description	Unit
F18-01	QJM42820A0R07	前左保险杠组合	Bumper comp., front, LH	PC
F18-02	QJM42810A0R07	前右保险杠组合	Bumper comp., front, RH	PC
F18-03	QJM41790A1A00	车架装饰罩组件	Ornament set, frame	PC
F18-04	QJM42840A0B01	保险杠支架组件	Bracket set, bumper	PC
F18-05	QJM42980A0B01	保险杠前连接板组件	Plate set, bumper front connecting	PC
F18-06	QJM42710A0B01	发动机前连板组件	Plate set, engine front connecting	PC
F18-07	QIC42955A0A00	后搁脚支架安装胶套	Rubber, Passenger Footrest Comp.	PC
F18-08	QIC42954A0N04	后搁脚支架安装衬套	Rubber, Passenger Footrest Comp.	PC
F18-09	QJM46530A0A00	座垫锁拉索	Cable, seat lock	PC
F18-10	DTX48340A0N01	座垫锁座组件	seat lock	PC
F18-11	QJM31810A0B01	蓄电池支架组合	Stay comp., battery	PC
F18-12	QJM45531A0B03	左后扶手	Handrail, LH	PC
F18-13	QJM45511A0B03	右后扶手	Handrail, RH	PC
F18-14	QJM44341A0B01	后座垫前连接板	Plate, pillion front connecting	PC
F18-15	QJM41100A0B12	车架焊接总成	Body weldment, frame	PC
F18-16	QJZ32952A0B01	主电缆线夹	Clamp, Cable, main	PC

LF150-10M F-19 电器 ELECTRICAL ELEMENTS

F-19 电器 ELECTRICAL ELEMENTS



04



03



02



01

Id		PartName	Description	Unit
F19-01	WIA31500A1A00	蓄电池	Battery	PC
F19-02	QMA38210A0A00	闪光继电器	Relay, flashing	PC
F19-03	QJZ38100A1B01	喇叭	Horn	PC
F19-04	QJM32100A0A00	主电缆	Cable, main	PC

157FMJ-3 E-01 气缸、气缸头 CYLINDER BLOCK & CYLINDER HEAD
 E-01 气缸、气缸头 CYLINDER BLOCK & CYLINDER HEAD



Id	Part No.	PartName	Description	Unit
E01-01	XXXXXXXXXXXXXX	单向阀通气管组合	Check Valve Vent Pipe Comp.	PC
E01-02	XXXXXXXXXXXXXX	单向阀通气管垫片	Check Valve Vent Pipe Shim	PC
E01-03	BJX12313AOM01	发动机盖形螺母	Cap nut M8	PC
E01-04	GIA12271A0A00	气缸头垫圈	Copper washer, bolt, cylinder	PC
E01-05	BJF12210A1B02	气缸头组合	Head unit, cylinder	PC
E01-06	BJX34210A0A00	火花塞	Spark plug	PC
E01-07	FJA17310A9Z50	进气管组件	Inle pipe set	PC
E01-08	BJF12110A1B02	气缸体组合	Block unit, cylinder	PC
E01-09	GJZ12121A0A00	气缸体密封垫	Gasket, cylinder block	PC
E01-10	BJF12221A0A00	气缸头密封垫	Gasket, cylinder head	PC
E01-11	BJF12242A2B02	气缸头左盖	Cover, cylinder head, LH	PC
E01-12	Q1270845F32	螺柱M8×45-Zn c1B	Bolt, M8×45	PC
E01-13	BIA12247A0A00	气缸头左盖O型圈	Gasket, cover, cylinder head, LH	PC
E01-14	BJX14137A0N02	凸轮轴挡板	Retainer, distributing camshaft	PC
E01-15	PIF12246A0A00	气门盖O型圈	Valve Cover O-Ring	PC
E01-16	MGY12243AOM01	气门盖	Cover, valve	PC
E01-17	BIA12218A0A00	气缸头定位销	Dowel pin, cylinder headΦ10×20	PC
E01-18	GIA11118A0A00	曲轴箱定位销Φ10×14	Dowel pin, cylinder headΦ10×14	PC
E01-19	BIA14519A1A00	张紧器密封垫	Washer, Tensioner	PC
E01-20	BLA14500A3B02	张紧器总成	Tensioner Assy	PC

157FMJ-3 E-02 配气机构 VALVE TRAIN
E-02 配气机构 VALVE TRAIN

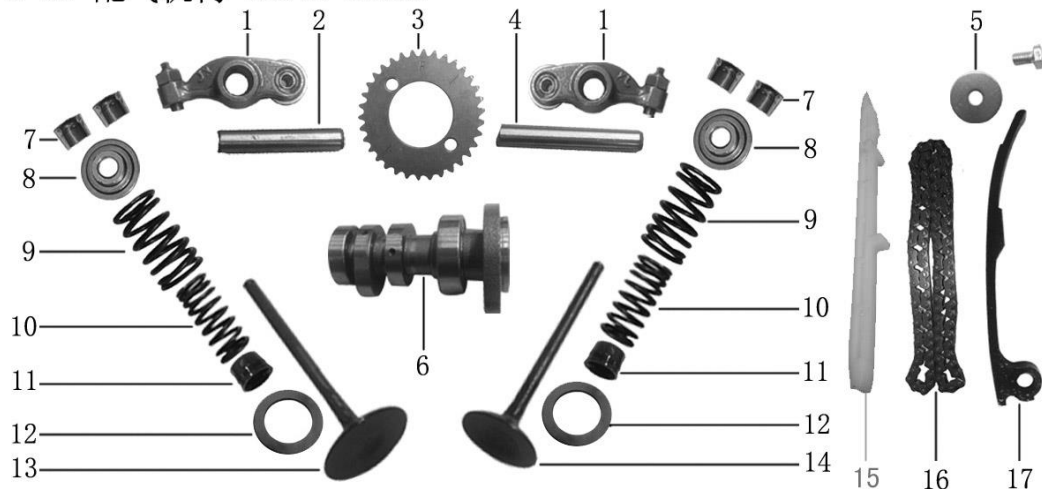

Id	Part No.	PartName	Description	Unit
E02-01	BJX14410A0A00	摇臂装配组合	Rocker arm Assy,	PC
E02-02	BJF14421A0A00	摇臂轴 II	Shaft, rocker arm II	PC
E02-03	FJA14321A0A00	正时从动链轮	Sprocket, timing driven	PC
E02-04	BJF14413A0A00	摇臂轴	Shaft, rocker arm I	PC
E02-05	XXXXXXXXXXXXXX	张紧板垫圈	Washer, tensioning plate	PC
E02-06	BJF14100A0A00	凸轮轴装配组合	Camshaft Assy I	PC
E02-07	PGA14752A0A00	气门锁夹	Split cone, valve	PC
E02-08	BJX14751A0A00	气门弹簧上座	Seat, spring, upper	PC
E02-09	BJF14755A0A00	气门外弹簧	Spring, valve, outer	PC
E02-10	BJX14756A0Z50	气门内弹簧	Spring, valve, inner	PC
E02-11	PGA14730A0A00	挡油罩	Oil seal, valve stem	PC
E02-12	PGA14753A0A00	气门外弹簧座	Valve Outer Spring Seat	PC
E02-13	BJX14710A0Z04	进气门	Valve, intake	PC
E02-14	BJX14720A0Z04	排气门	Valve, exhaust	PC
E02-15	BJF14610A1A00	导向板	Guiding plate	PC
E02-16	FJA14350A0A00	正时链条	Chain, timing	PC
E02-17	BJF14650A0A00	张紧板	Tensioner	PC

157FMJ-3 E-03 右曲轴箱盖 RIGHT CRANKCASE COVER
 E-03 右曲轴箱盖 RIGHT CRANKCASE COVER



Id	Part No.	PartName	Description	Unit
E03-01	FJA22810AOM01	离合器操纵杆组合	Clutch Controlling Rod	PC
E03-02	GIA22840A0A00	离合器操纵杆油封	Clutch Lever Oil Seal	PC
E03-03	FJA22821A0Z50	离合器操纵杆弹簧	Clutch Lever Spring	PC
E03-04	BIA22825A0A00	离合器操纵杆定位销	Spring, operating shaft, clutch	PC
E03-05	GIB15610A0A00	机油尺组合	Dipstick comp.	PC
E03-06	BIA15612A0A00	机油尺O型圈	O-ring, dipstick	PC
E03-07	GIA27190A2A00	起动轴油封	Oil seal, starting shaft	PC
E03-08	BJF11310-0021	右曲轴箱盖组合	Cover comp., crankcase, RH	PC
E03-09	GLQ22824A1M01	离合器拉索调节架	Stay, clutch cable adjusting	PC
E03-10	GJZ11319A1A00	右曲轴箱盖密封垫	Gasket, crankcase cover, RH	PC
E03-11	GIA15620A0A00	机油观察窗	Glass, sight	PC
E03-12	PGA12218A0A00	右曲轴箱盖定位销	Head, cylinder Set Pin	PC

157FMJ-3 E-04 曲轴箱 CRANKCASE

E-04 曲轴箱 CRANKCASE

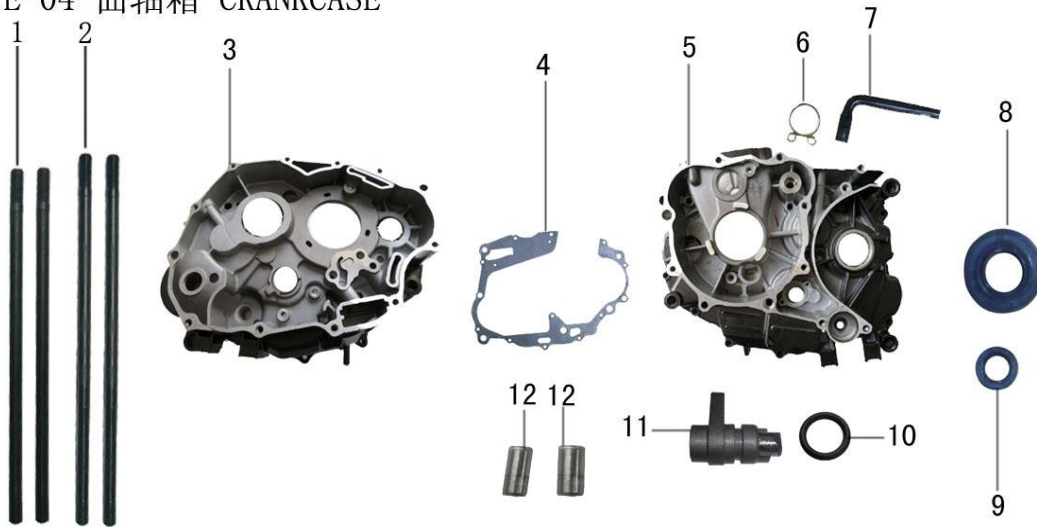

Id	Part No.	PartName	Description	Unit
E04-01	Q983B082014207	气缸螺栓M8×207	Stud AM8×207	PC
E04-02	Q983B082014212	气缸螺栓M8×212	Stud BM8×212	PC
E04-03	GJZ11110A0B02	右曲轴箱组合	Crankcase, RH	PC
E04-04	GJZ11119A0A00	曲轴箱密封垫	Gasket, crankcase	PC
E04-05	GJZ11210A0B02	左曲轴箱组合	Crankcase, LH	PC
E04-06	GIA20153A0N01	曲轴箱废气管管夹	Clip, exhaust pipe	PC
E04-07	GIA20152A0A00	曲轴箱废气管	Pipe, exhaust	PC
E04-08	GIA23790A1A00	副轴油封	Oil seal,	PC
E04-09	GIA24190A1A00	变档轴油封	Oil seal, gearshift shaft	PC
E04-10	XXXXXXXXXXXXX	压销体O型圈	pin-keeping O-Ring	PC
E04-11	GIA11230A0A00	压销体组合	Body comp., pin-keeping	PC
E04-12	GIA11118A0A00	曲轴箱定位销	Dowel pin (Φ10×14)	PC

157FMJ-3 E-05 机油泵、起动电机 OIL PUMP & STARTING MOTOR
 E-05 机油泵、起动电机 OIL PUMP & STARTING MOTOR



Id	Part No.	PartName	Description	Unit
E05-01	GJZ15100A1A00	机油泵总成	Oil Pump Assy	PC
E05-02	GIA34700A0B02	起动电机总成	Starting motor	PC
E05-03	GIA28321A0A00	双联齿轮轴	Shaft, dual-gear I	PC
E05-04	GIA28312A0A00	双联齿轮垫圈	Washer, Dual-gear	PC
E05-05	GIA28310A0A00	双联齿轮组合 I	Dual-gear comp. I	PC
E05-06	BJY28150A1A00	起动离合器齿轮组合	Gear set, starting clutch	PC
E05-07	GIA28341A0A00	双联齿轮轴 II	Dual-gear comp. II	PC
E05-08	GIA28341A0A00	双联齿轮轴 II	Shaft, dual-gear II	PC
E05-09	GIA28312A0A00	双联齿轮垫圈	Washer, Dual-gear II	PC
E05-10	GJZ15131A0A00	机油泵密封垫	Oil Pump Gasket	PC

157FMJ-3 E-06 磁电机 MAGNETO

E-06 磁电机 MAGNETO

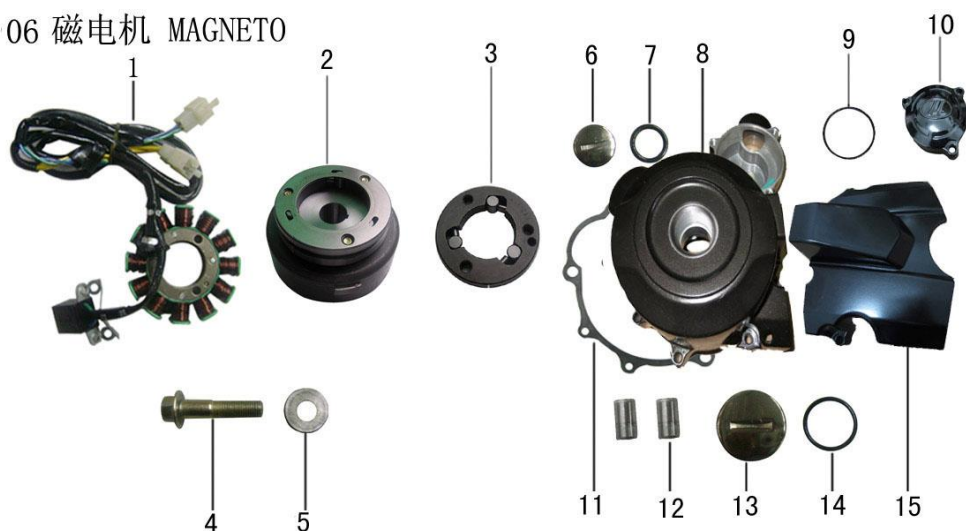

Id	Part No.	PartName	Description	Unit
E06-01	GIX31210A2A00	磁电机定子组合	Stator set, magneto	PC
E06-02	BJF31102A0A00	磁电机转子装配组合	Flywheel clutch Assy	PC
E06-03	BJY28150A1A00	起动离合器齿轮组合	Starting clutch Assy	PC
E06-04	GIA31913A0Z01	磁电机螺栓	Bolt,	PC
E06-05	MIY31312A0N04	磁电机紧固螺母垫圈	Thrust washer	PC
E06-06	PGB11412A0M01	观察孔螺塞	Plug, watch hole	PC
E06-07	BIA11414A0A00	观察孔螺塞O型圈	O-ring, watch hole plug	PC
E06-08	BJF11411-0003	左曲轴箱盖	Cover, crankcase, LH	PC
E06-09	GIA11422A0A00	过轮盖O型圈	O-ring, $\Phi 63 \times \Phi 3$	PC
E06-10	GIA11421A6M01	过轮盖	Cover, upper	PC
E06-11	GIA11419A3A00	左曲轴箱盖密封垫	Gasket, crankcase cover, LH	PC
E06-12	GIA11118A0A00	曲轴箱定位销	Dowel pin, crankcase	PC
E06-13	GIA11413A0M01	螺塞	Cover, LH	PC
E06-14	BIA11415A0A00	螺塞O型圈	O-ring, plug,	PC
E06-15	BJF11451A1B02	左后盖	Rear cover, LH	PC

157FMJ-3 E-07 离合器 CLUTCH
E-07 离合器 CLUTCH

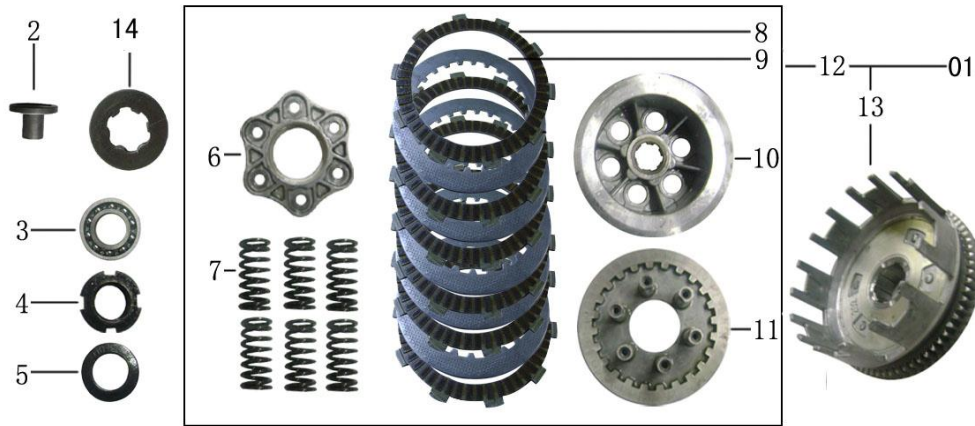

Id	Part No.	PartName	Description	Unit
E07-01	BIA22100A3A00	离合器主体组合	Body, clutch	SET
E07-02	FJA22861A0A00	离合器推杆	Clutch Pusher	PC
E07-03	Q96516003	滚动轴承16003	Bearing, 16003	PC
E07-04	PGZ22151	离合器紧固螺母	Lock nut	PC
E07-05	GIA22632A0A00	初级主动齿轮止退垫圈	Thrust washer	PC
E07-06	GIA22361A5	离合器端盖	Plate, clutch lifter	PC
E07-07	GIA22371A2	离合器弹簧	Spring, Clutch	PC
E07-08	GIA22330	离合器主动片	Disc set, clutch friction	PC
E07-09	GIA22341A1	离合器从动片	Plate, clutch	PC
E07-10	GIA22351A2	离合器压盘	Plate, clutch pressure	PC
E07-11	GIA22320A8	离合器从动盘组合	Center comp., clutch	PC
E07-12	GIA22310A8	离合器从动盘装配组合	Clutch Assy	PC
E07-13	BIA22110A1	离合器主动盘组合	Outer comp., clutch	PC
E07-14	GIA22372A0A00	离合器花键垫圈	Spline washer	PC

157FMJ-3 E-08 曲轴、活塞 CRANKSHAFT & PISTON
 E-08 曲轴、活塞 CRANKSHAFT & PISTON



Id	Part No.	PartName	Description	Unit
E08-01	MIA13222A0A00	活塞销挡圈	Circlip, piston pin	PC
E08-02	FJA13221A0A00	活塞销	Pin, piston	PC
E08-03	FJA13211A0Z03	活塞	Piston	PC
E08-04	BJF13100A0A00	曲柄连杆组合	Rod comp., crankshaft connecting	PC
E08-05	PGA13118A0A00	曲轴半圆键	Key, woodruff	PC
E08-06	FJA13300A0A00	活塞环组	Ring set, piston	SET
E08-07	Q9656328P5C	滚动轴承63/28P5/CJB	Bearing, crankshaft, RH	PC
E08-08	FB093850A3A00	滚动轴承15×35×11	Bearing,	PC
E08-09	GJZ13611A0A00	平衡轴	Shaft, balanced	PC
E08-10	PGA13118A0A00	曲轴半圆键	Key, woodruff	PC
E08-11	FJA13641A0A00	平衡轴从动齿轮	Gear, balanced shaft driven Assy	PC
E08-12	FJA13631A0A00	平衡轴主动齿轮	Gear, balanced shaft drive	PC
E08-13	GMF22621A0A00	初级主动齿轮	Gear, primary drive	PC
E08-14	FJA13643A0Z02	初级主动齿轮碟形垫圈	Thrust washer	PC
E08-15	GIA22631A0A00	初级主动齿轮紧固螺母	Lock nut	PC

157FMJ-3 E-09 传动装置 TRANSMISSION
E-09 传动装置 TRANSMISSION

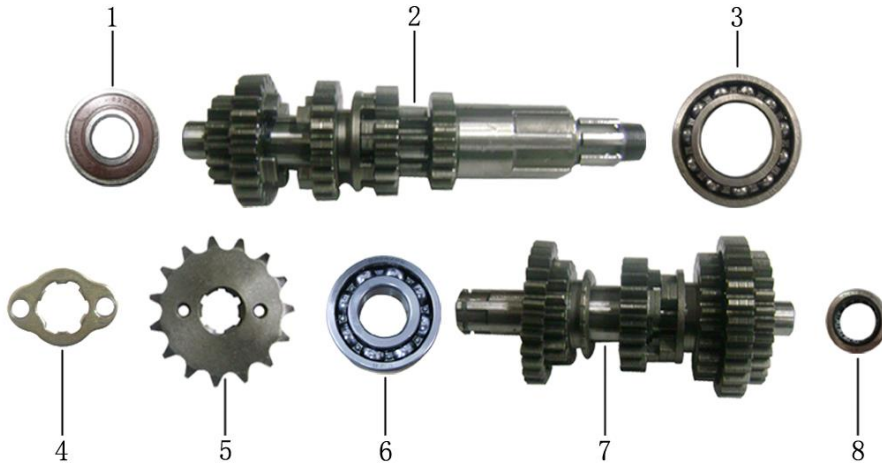

Id	Part No.	PartName	Description	Unit
E09-01	Q965D6202F	滚动轴承6202RS	Bearing, 6202 RS	PC
E09-02	GJZ23600A0A00	主轴组合	Main shaft Assy	SET
E09-03	Q9656006P6F	滚动轴承6006P6/FJK	Bearing, 6006	PC
E09-04	GIA22712A0N03	输出链轮固定板	Locating plate, sprocket	PC
E09-05	GIA22711A1Z52	输出链轮	Sprocket, output	PC
E09-06	Q9656204P6F	滚动轴承6204/P6/FJK	Bearing, 6204	PC
E09-07	GJZ23700A0A00	副轴组合	Countershaft Assy	SET
E09-08	Q9611512	滚动轴承HK152312	Bearing, needle, HK152312	PC

157FMJ-3 E-10 变档机构 GEARSHIFT DEVICE
 E-10 变档机构 GEARSHIFT DEVICE

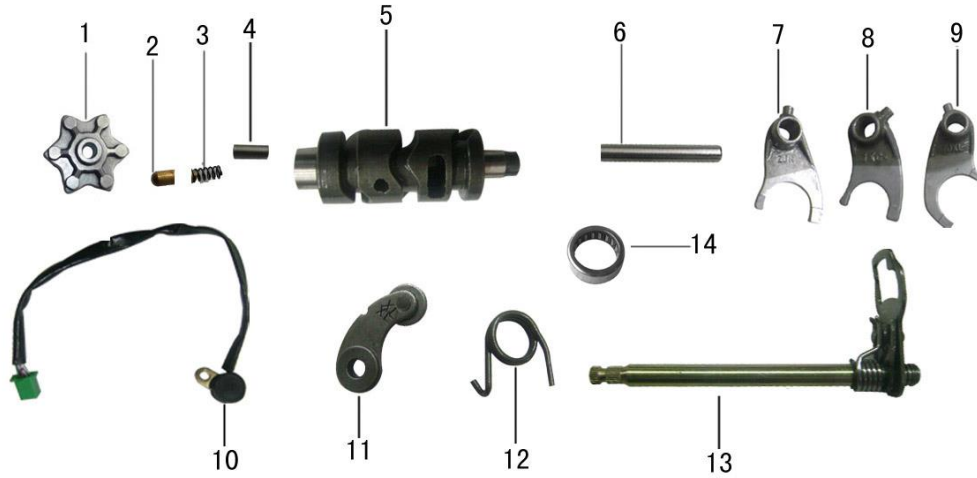

Id	Part No.	PartName	Description	Unit
E10-01	GIA24221A1A00	变档轮	Cam	PC
E10-02	BJA24212	档位指示销	Pin, gear indicating	PC
E10-03	BJA24213	指示销弹簧	Spring, Pin	PC
E10-04	GIA24222	变档轮定位销	Set pin,	PC
E10-05	GJZ24210A1A00	变档凸轮组合	Drum	PC
E10-06	BIA24421A0A00	变档拨叉轴	Shaft, fork	PC
E10-07	GJZ24413A0A00	拨叉III	Fork (III)	PC
E10-08	GJZ24412A0A00	拨叉II	Fork (II)	PC
E10-09	GJZ24411A0A00	拨叉I	Fork (I)	PC
E10-10	GIA35710A4A00	档位指示器	Indicator, gear	PC
E10-11	GIA24310A3A00	档位定位板组合	Limit plate	PC
E10-12	GIA24323A1A00	定位板扭簧	Spring	PC
E10-13	GID24100A3N03	变档轴总成	Gearshift shaft Assy	PC
E10-14	GIA93840A0A00	滚针轴承21×28×10	Bearing, needle	PC

157FMJ-3 E-11 化油器、变档杆 GEARSHIFT PEDAL & CARBURETOR
 E-11 化油器、变档杆 GEARSHIFT PEDAL & CARBURETOR

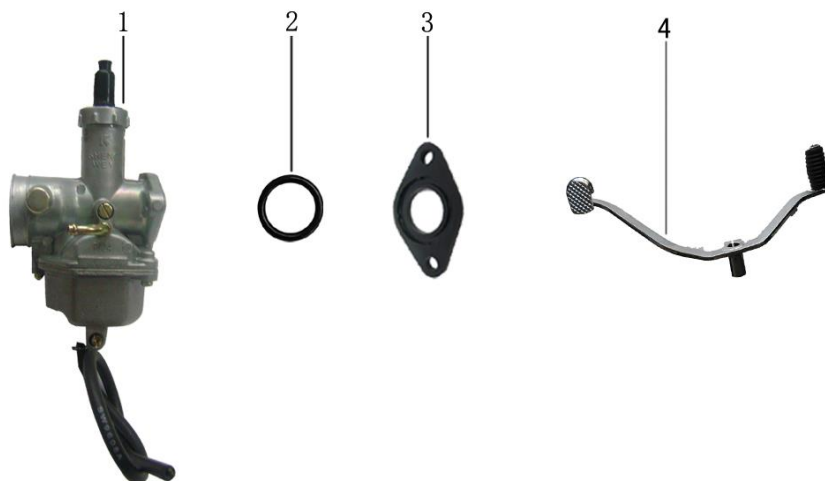

Id	Part No.	PartName	Description	Unit
E11-01	BJF16100A2A00	化油器总成	Carburetor Assy	PC
E11-02	PHY17318A0A00	进气管O型圈	Inlet Pipe Insulator O-Ring	PC
E11-03	PHY17331A0A00	进气管隔热垫	Inlet Pipe Insulator	PC
E11-04	GIA24700G8M01	变档杆总成	Gearshift pedal Assy	PC

157FMJ-3 E-12 电器 ELECTRIC ELEMENTS
 E-12 电器 ELECTRIC ELEMENTS



Id	Part No.	PartName	Description	Unit
E12-01	GIA34400B3A00	点火控制器	Ignition Controller	PC
E12-02	GIA34600A0A00	起动继电器	Start Relay	PC
E12-03	GIA31600A8A00	电压调节器	Voltage Regulator	PC
E12-04	GIA34500A4A00	点火线圈	Ignition Coil	PC